



13000 South Broadway
Los Angeles, CA 90061
Tel 800-321-8178
Fax 310-767-1714

TERMINATION & SPLICING OF ZIPPERTUBING®

(ZT94-98-002)

The following procedure describes “generic” methods for splicing and terminating shielded Zippertubing products when applied over electrical cables. The methods described are of typical installations and may not always apply to a customer’s unique installation situation. The goal of this document is to provide the installer with several different termination methods that have been proven to provide a good electrical and mechanical splice. The methods described are intended to act as an idea guide only and do not reflect all possible methods. Many of the following illustrations depicted in this document show the Zippertubing with a mechanical zipper type of closure. This has been done for simplicity and the procedures described apply to most closure mechanism types.

CAUTION: Before attempting any cable repairs or modification, insure that the power is disconnected, locked out and suitably tagged!

SHIELD SPLICING

There are several methods of electrically and mechanically joining several pieces of EMI shielded Zippertubing together. The following illustrations depict several methods of achieving good electrical and mechanical joints. They vary depending on the end use application and environmental condition to which they are exposed. These are by no means the only methods possible.

1) “Lap Splicing”

This method involves removing the jacket insulation (or folding the jacket inside-out; thin materials only) for a distance of several inches from the jacket end and installing the next piece of shielding over the exposed metal shield of the first jacket. The pieces can be held together using plastic or metal cable ties. This technique is generally acceptable in applications where the finished cable assembly is not subject to post assembly movement (Figures 1 and 2).

2) Splicing Grounding Braids

This technique is a slight variation of the “Lap-Splice” method described above. It involves removing a small amount of the stitching holding the grounding braid straps to the shielding material at the ends of the two pieces of Zippertubing shielding which is to be spliced. Once the braid straps are loose, the two ends can be butt-spliced together using a standard 14-16 AWG crimp style butt splice

(Figure 3). Once the braids have been spliced together the shields can be “lap-spliced” and mechanically tied (Figure 2).

3) Soldering Shield Material (SHX2, SHX4 and Zipper-Mesh® Only)

This method applies to the SHX2, SHX4 and Zipper-Mesh® type of shielding materials only. The procedure involves removing one-inch of jacketing material from the two ends of the jackets to be spliced, lapping the shield material over one another (as described above) and then soldering the shield materials together. The shield material in these products is made from Tin plated, copper clad, steel wire mesh and will solder easily using 63/37 Tin/Lead solder. Use an “RMA” cleaning flux prior to soldering to eliminate any oxidation of the Tin plated surfaces that may have developed since the shield was manufactured. The lap splice joint may be spot soldered or the entire perimeter may be soldered depending on the degree of mechanical strength the application demands. Keep in mind that soldering will make the joint area rigid. Clean the solder joint with Isopropyl Alcohol (IPA) or equivalent and allow the solvent to evaporate completely. Wrap the solder joint area and the insulation jacket material back several inches from the solder joint using Polyurethane ZT-Tape-8235® adhesive backed electrical tape. (Figure 4 and 5)

SHIELD TERMINATION

Shield termination to a good ground source is extremely important to over all system performance. The installer should consult any in-house installation drawings, process procedures or the systems engineer prior to making any terminations. Some applications may require that only one end of the shield is terminated while others may require both ends to be terminated. Many times it may not be possible to make the “ideal” termination due to hardware variations or a retrofit installation. The following methods are examples of typical termination scenarios and the Zippertubing Company does not indorse one method over another. All of the termination methods described below have been used with success in the past. However, your specific system requirements may dictate the use of one method versus another.

1) “Pigtail’ Termination

This method involves creating a drain wire extension to reach from the end of the shielding jacket to the intended grounding point. This can be achieved three different ways depending on the secondary materials available. All three methods create a ground wire pigtail that can be soldered or crimped to terminal hardware for attachment to the grounding surface (Figure 6).

IMPORTANT: To obtain the best overall shielding performance from a Zippertubing shielded jacket it is very important to plan the installation so the drain wire (pigtail) length is kept as short as possible.

Option 1. This method involves soldering a grounding lead, of the desired length, directly to the Tin plated Copper braid wire that is sewn into the shield material prior to zipping the jacket on the cable.

Option 2. This method is somewhat similar but requires that approximately one-inch of the stitching holding the drain wire braid to the shield material be removed at the end of the shielded jacket. Once the braid wire is loose it can be mechanically spliced to a secondary wire using a standard 14-16 AWG crimp style butt splice.

Option 3. This method assumes that no secondary grounding wire is available. Insure that you have plenty of extra Zippertubing shielding material available prior to processing any assembly using this method. Remove the stitching hold in the drain wire braid to the shielding material the same distance required to reach the intended ground plane. Using a pair of scissors or shears and cut the shielding, jacket and zipper closure mechanism back the same distance (do not cut the drain wire braid). Be sure that you have enough of the shielded jacket material length available so that you don't come up short at the opposite end of the cable!

2) Connector Body or Chassis Feed-Thru Stub

Shield terminations can also be accomplished using the cable connector body as a ground path if the connector is of an electrically conductive material and is electrically bonded to a chassis ground. This requires that the Zippertubing shielding material be sized to largest diameter of the connector body rather than the wire bundle since the connector is usually larger. A metallic tubular stub feed thru extending from the chassis wall (similar a connector) is also an ideal mounting and ground location. By wrapping the Zippertubing around these components it is possible to achieve a 360-degree EMI seal which can be important, especially at the higher frequency ranges. Metal or plastic Banding Clamps or Tie-Wraps can provide the mechanical compression and jacket retention required to hold the jacket in place. (Figures 7 & 8)

Some Military style connectors have specialty back shell hardware such as a "saddle clamp" or an EMI "compression ring" that can also provide a conductive pathway to ground. These features may require that the outer insulation jacket material and closure mechanism be trimmed away to expose the conductive shield material and allow the material to fit into the tight spaces of the connector. Some Zippertubing shield and jacket combinations are very thin and may be thin enough to be folded back onto themselves to make the electrical contact required by the hardware. The installer will need to determine what approach is best based on the specific connector hardware being used. (Figures 9 & 10)

3) Splayed Shield End

This method can be used when cables pass through a bulkhead or enter a box that has no connector or feed-thru hardware available for termination of the shielded Zippertubing jacket. The process requires that the end of the

Zippertubing be fanned out or split into two flat tongues to allow placement of the shield material against the bulkhead wall. This approach may require the Zippertubing be sized larger than the cable diameter to provide enough material to cover the bulk of the wall opening and still allow for attachment to the wall. If the jacket is to pass through the hole and make contact with the inside wall, then the insulation jacket may need to be removed or folded back onto itself to insure that the shield material is in contact with the inside wall. This concept generally does not provide a 360-degree EMI seal but is usually superior to a pigtail grounding wire lead. The box or bulkhead surface must be electrically conductive and the installer shall determine the attachment hardware. (Figure 11.)

TRANSITIONS & BREAKOUTS

This process involves wrapping the transition or breakout area of the cable with a conductive shielding tape prior to installing the Zippertubing shielded jacket. Use one of Zippertubing's EMI shielding tapes that utilize materials similar to those found within the shielded Zippertubing jacket you intend to use. For Aluminum foil and knitted wire mesh shielded jackets use Zippertubing's "Zip-Mesh-AL" tape. For products utilizing metallized shielding fabric use "Z-3250-CN" shielding tape. Contact your local Zippertubing sales representative or Zippertubing directly for the correct materials and product part numbers.

- Step 1. Spirally wrap the wire bundle in the breakout area using the appropriate EMI shielding tape. Use a 50% overlap technique and cover each leg of the breakout 3 to 6 inches (exact dimension will vary with cable diameter) from the breakout crotch. Insure the that crotch area is fully covered. (Figure 12 and 13)
- Step 2. Install the individual pieces of Zippertubing shielded jacket material over each leg of the tape wrapped harness. You may wish to splice the ground braid wires (if applicable) from each leg of the shielded jackets together as previously described. Position all pieces as close to the crotch area as possible. (Figure 14)
- Step 3. Use Zippertubing's "ZT-Tape-8235" Polyurethane insulating tape and over wrap all legs of the breakout. Use a 50% overlap technique and insure that the crotch area is completely covered. Install string ties, cable ties or banding clamps to each leg of the taped assembly to insure good shield to shield contact and stop any shifting of the assembly. (Figure 15 and 16))

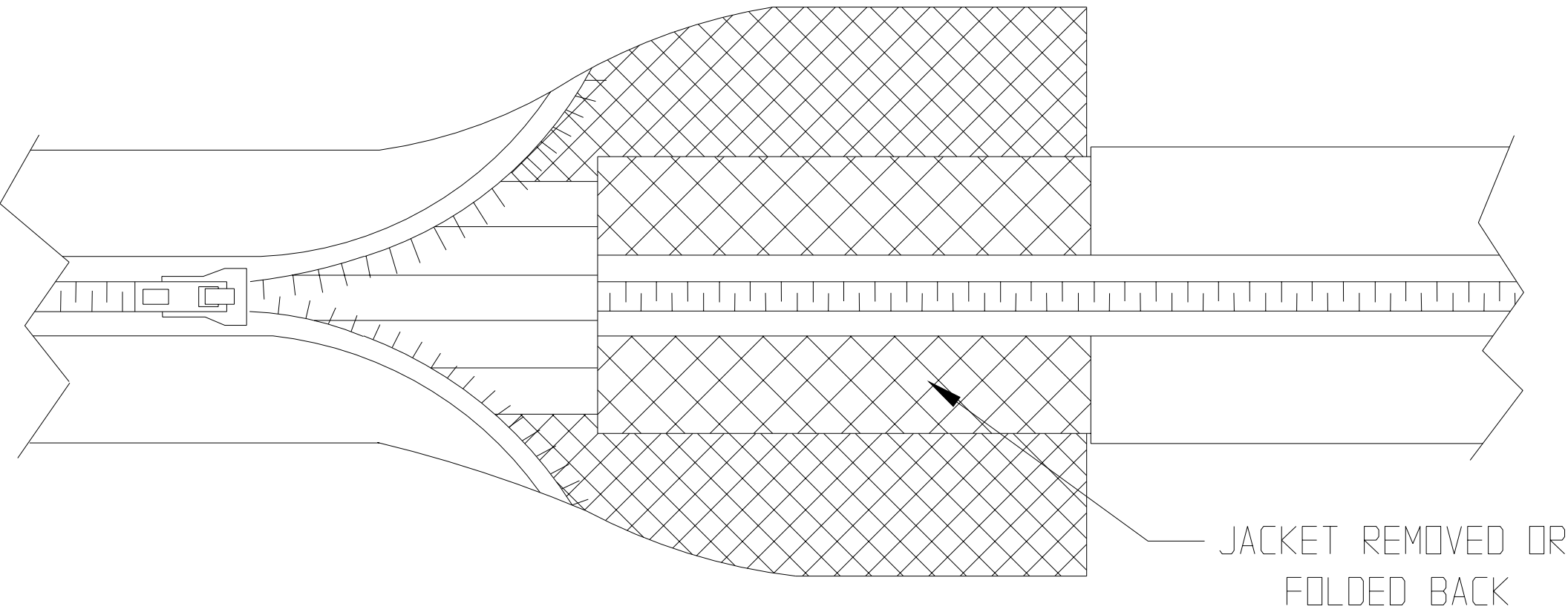

FIGURE 1. EMI SHIELD LAP SPLICE

PLASTIC or METAL CABLE TIES

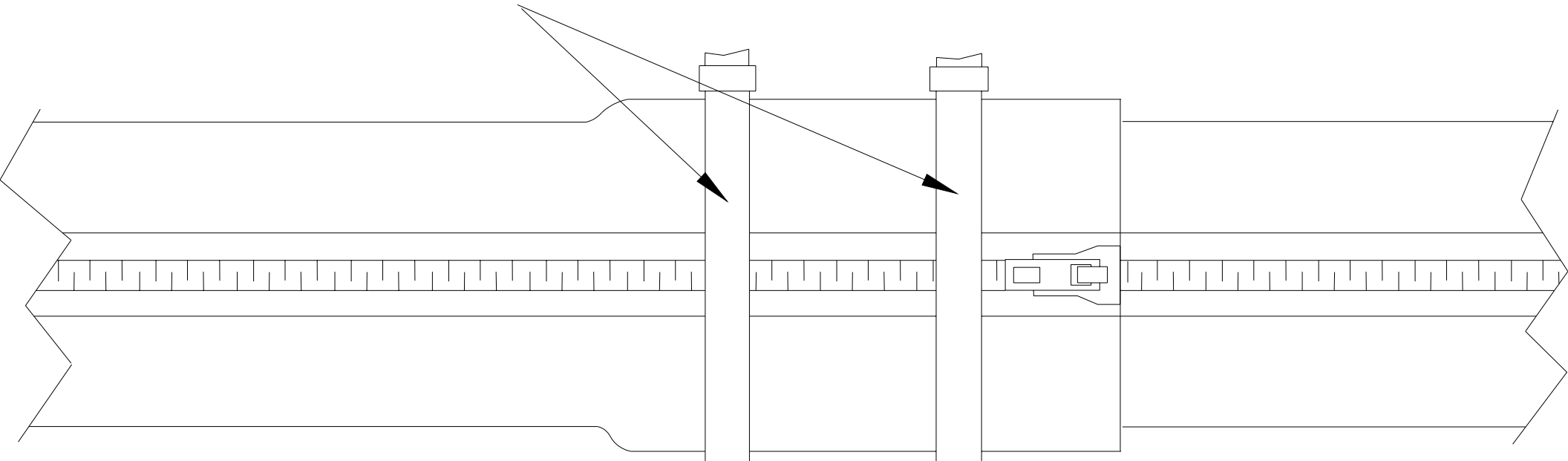

FIGURE 2. CABLE TIE RETENSION

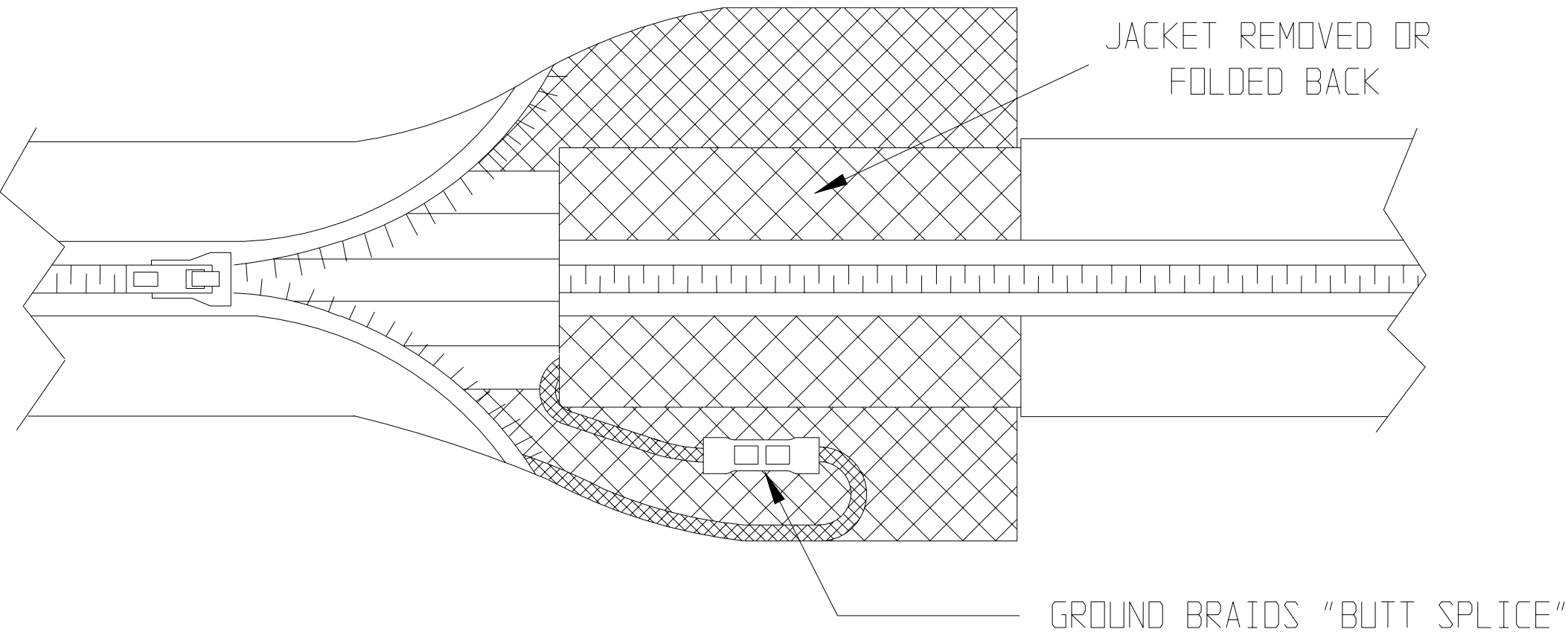

FIGURE 3. GROUND DRAIN SPLICING

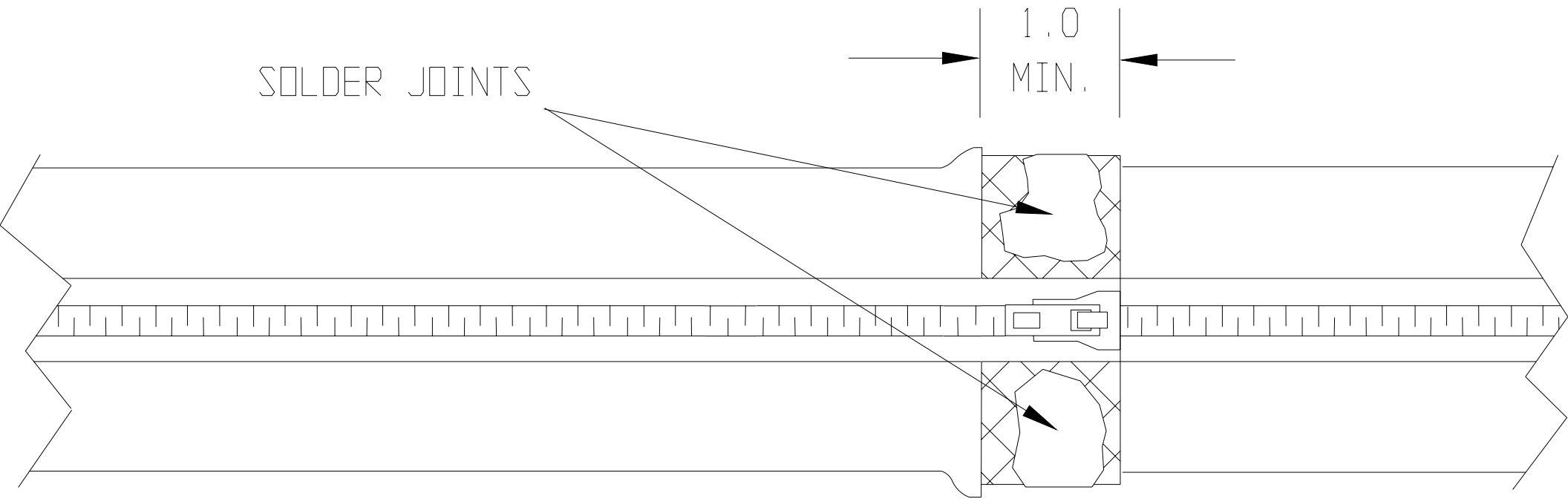

FIGURE 4. SOLDERED EMI SHIELD

ZT-TAPE-8235 WRAP

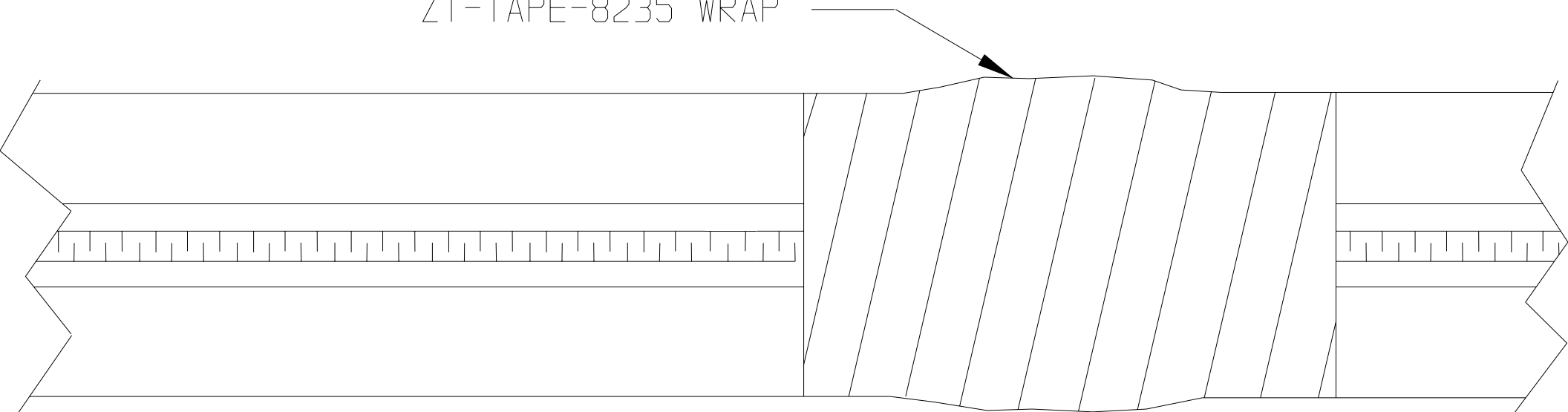
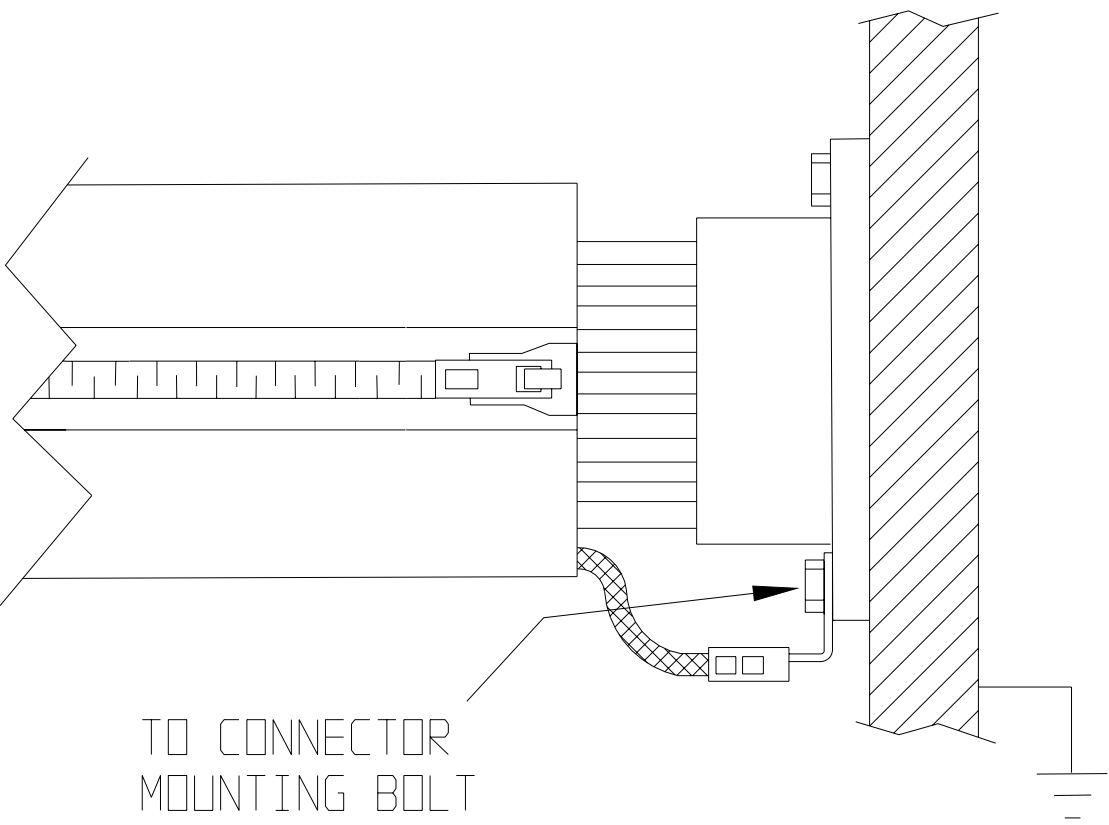
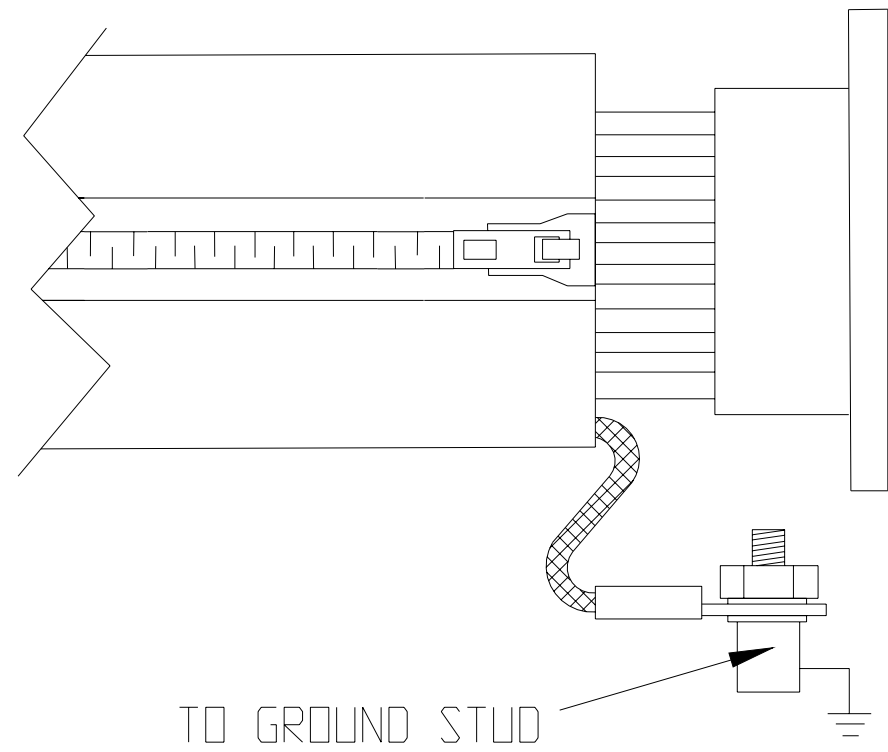

FIGURE 5. INSULATION TAPE WRAP



TO CONNECTOR
MOUNTING BOLT



TO GROUND STUD

FIGURE 6. PIGTAIL LEADS TO GROUND

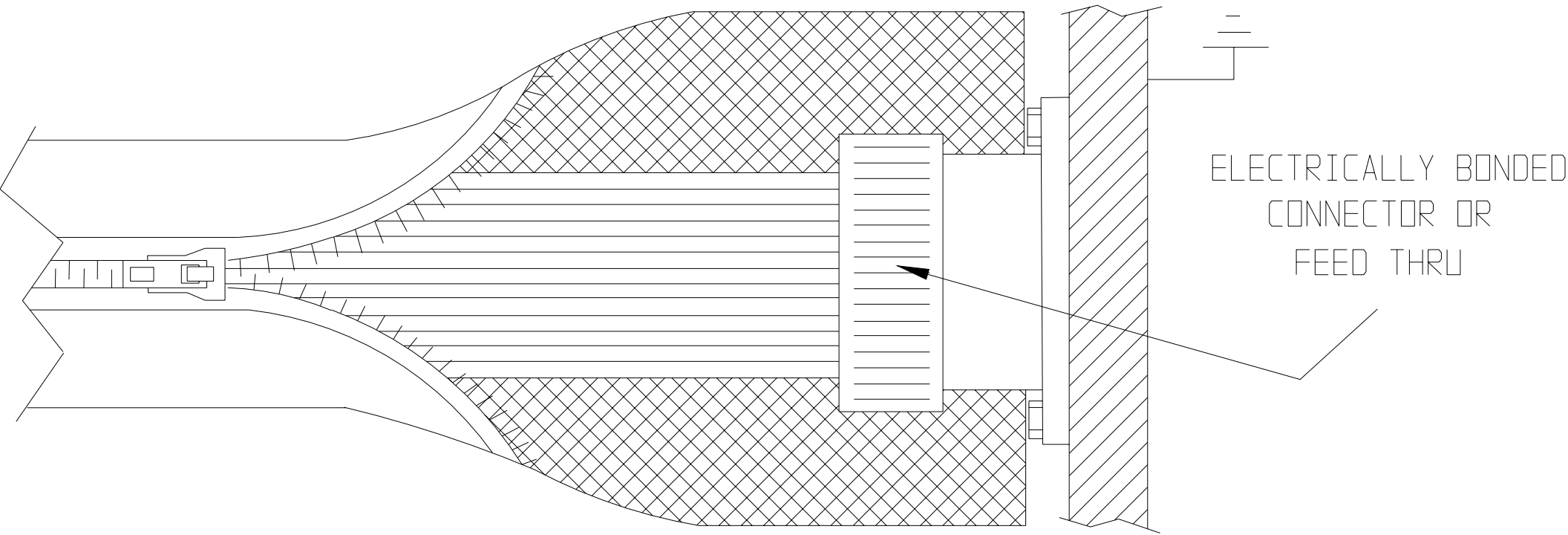

ELECTRICALLY BONDED
CONNECTOR OR
FEED THRU

FIGURE 7. SHIELD CONTACT TO CONNECTOR

PLASTIC OR METAL CABLE TIES

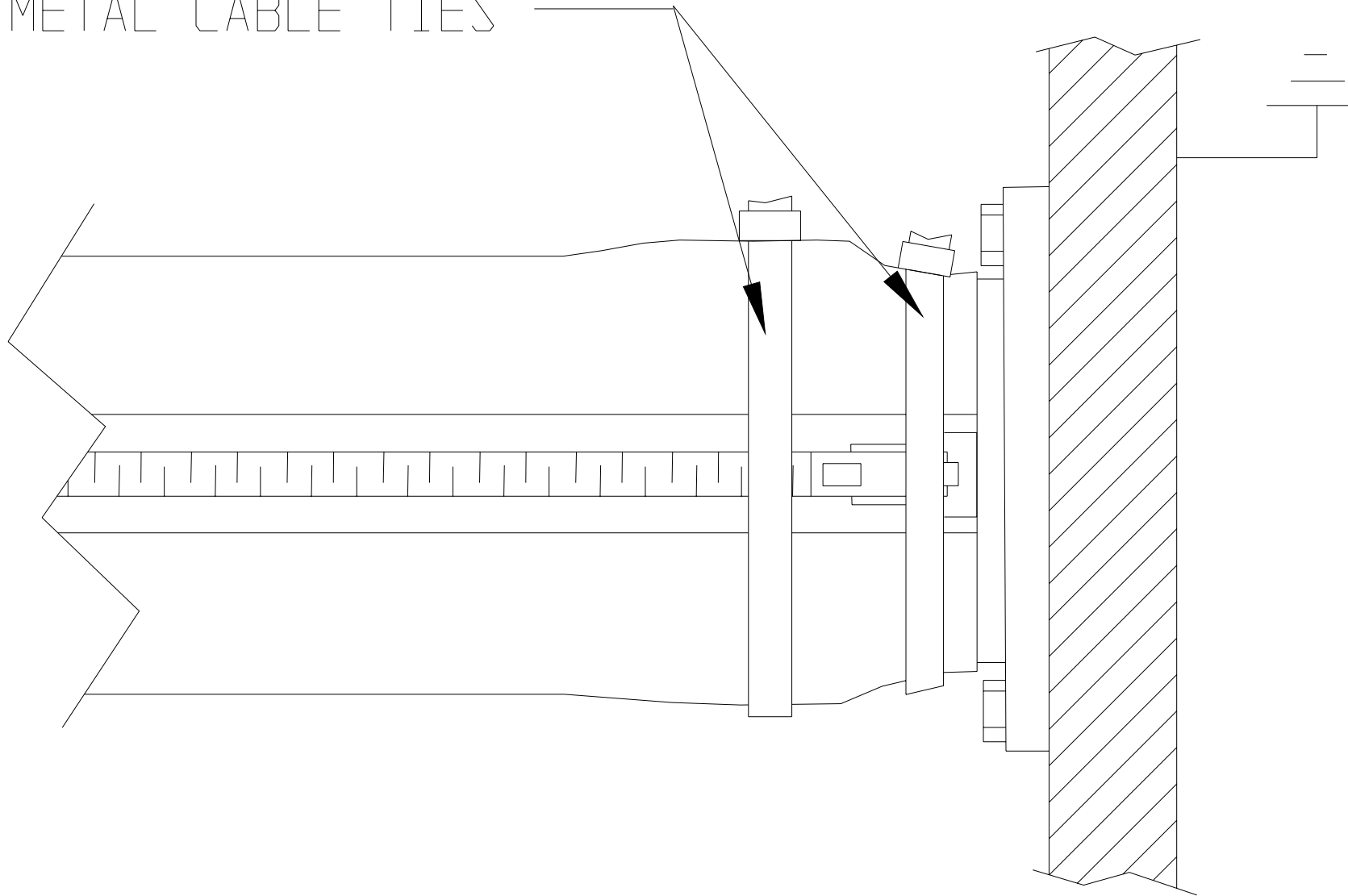

FIGURE 8. TIE-WRAP JACKET RETENTION

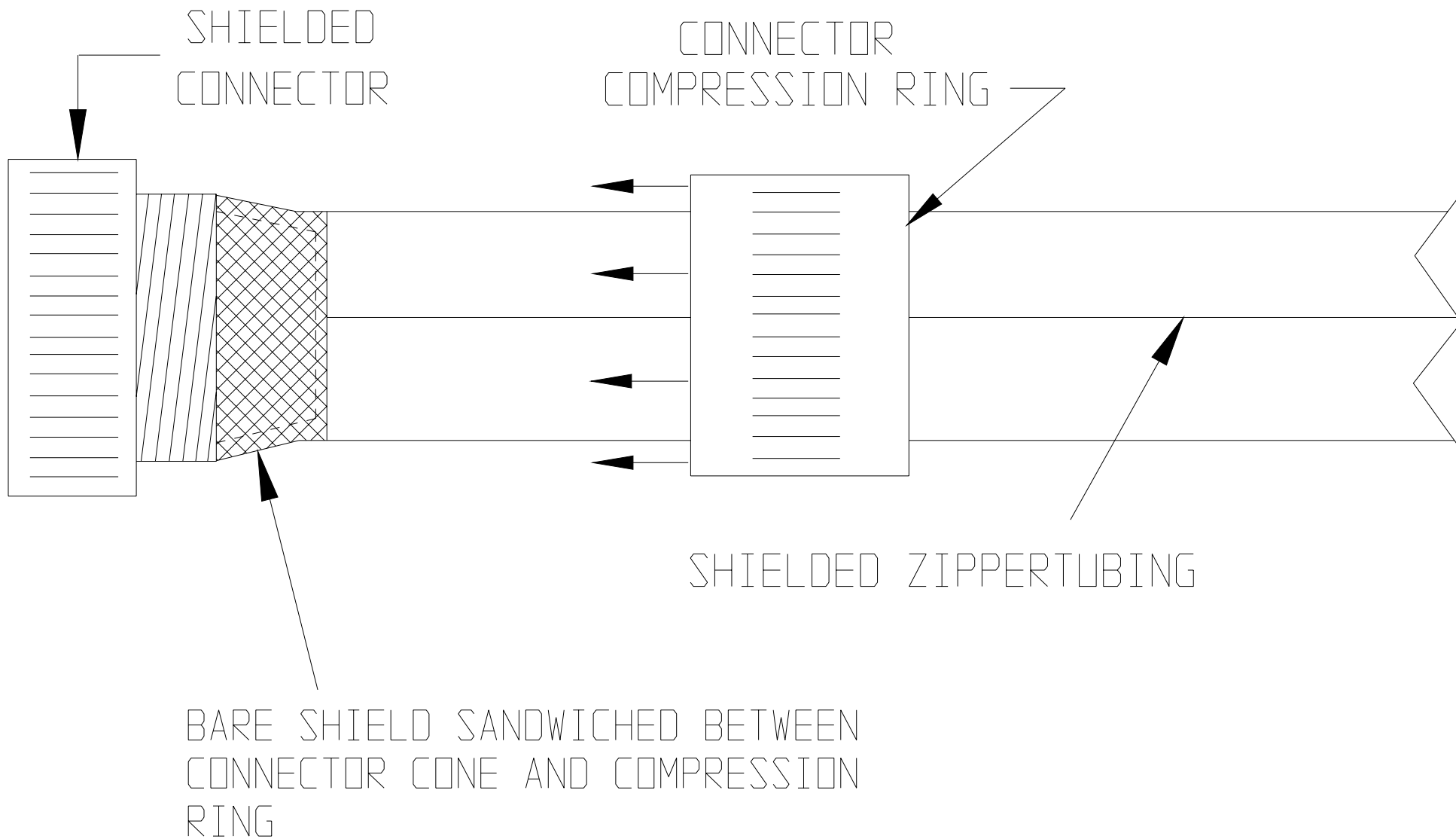
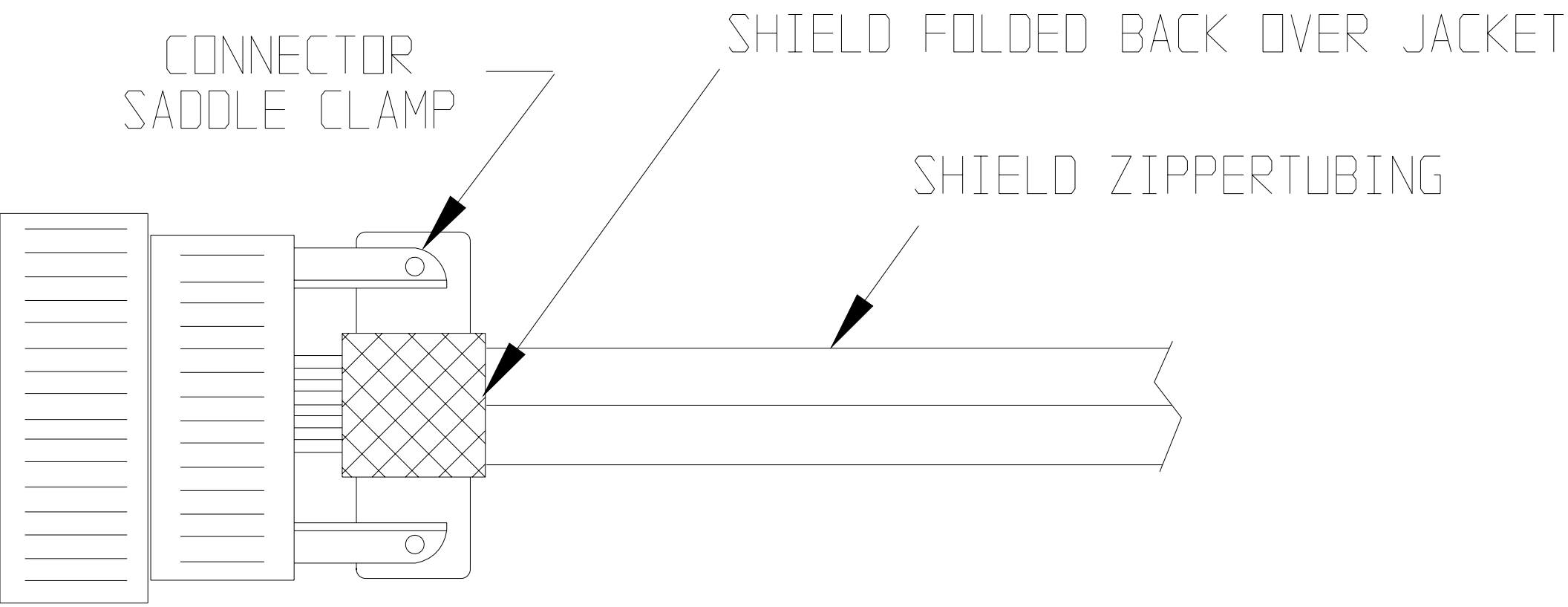

FIGURE 9. EMI CONNECTOR WITH SHIELD COMPRESSION RING



CONNECTOR
SADDLE CLAMP

SHIELD FOLDED BACK OVER JACKET

SHIELD ZIPPERTUBING

FIGURE 10. SHIELD UNDER SADDLE CLAMP

OUTSIDE
TERMINATION

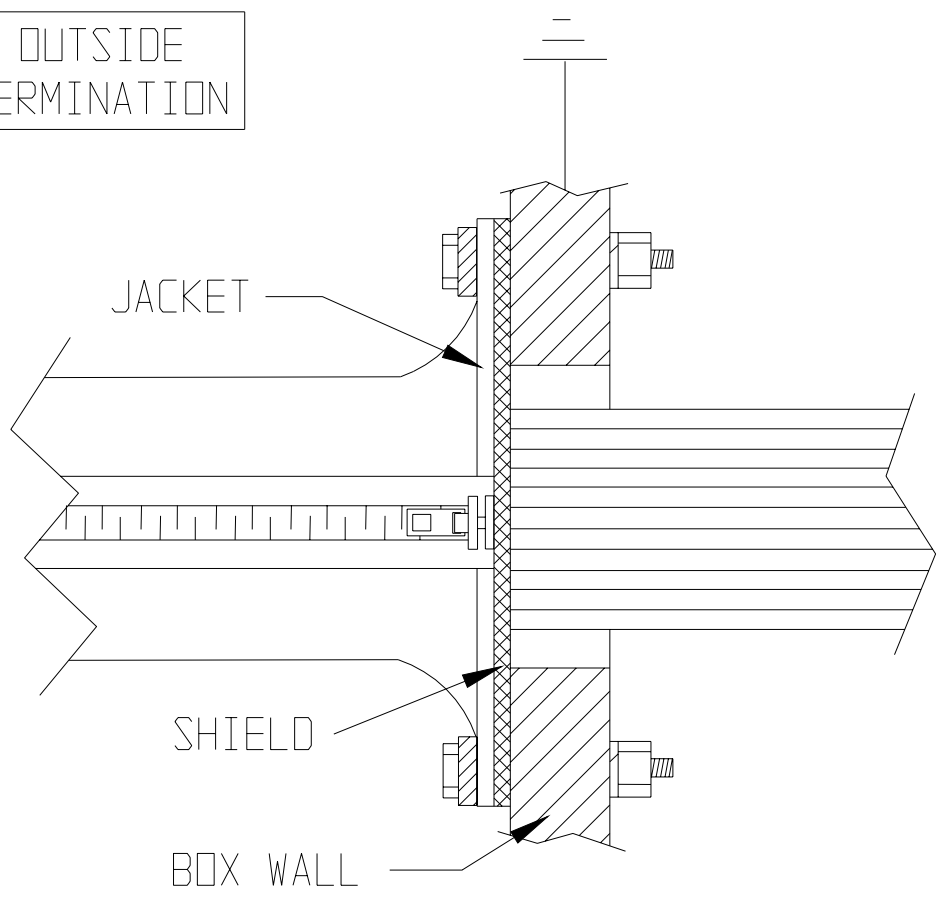

INSIDE
TERMINATION

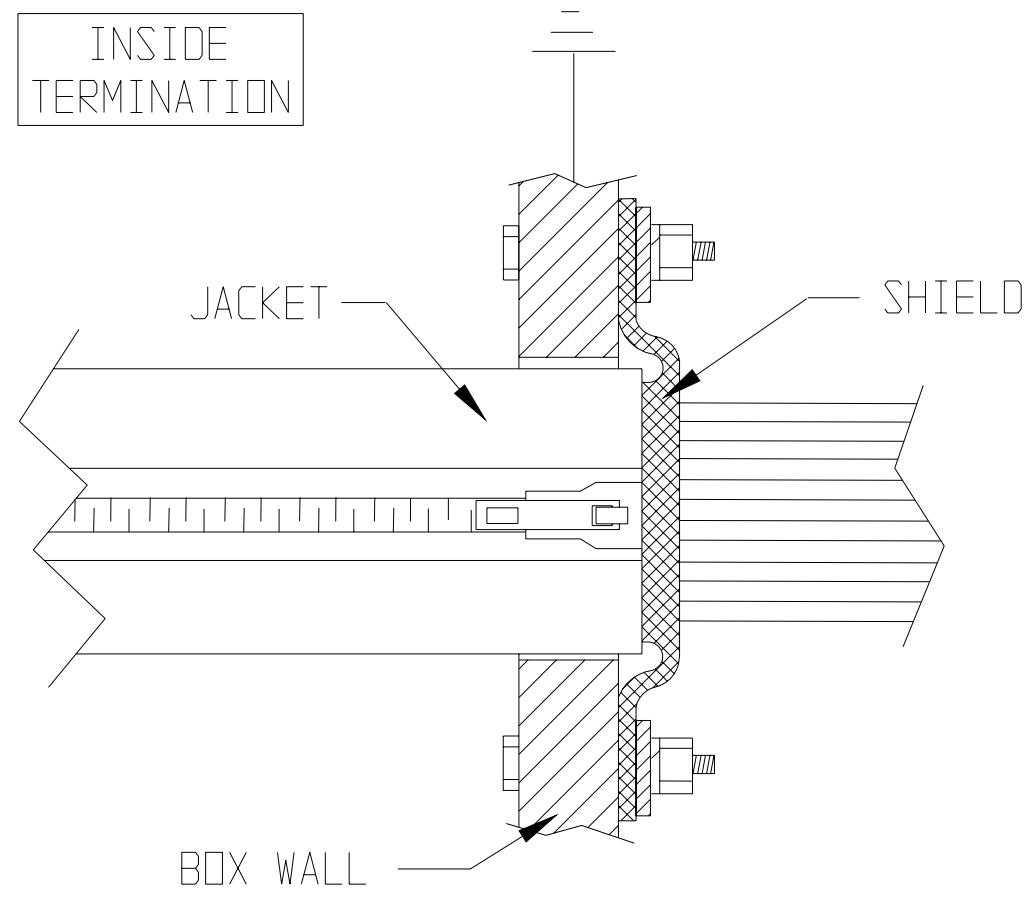

FIGURE 11. SHIELD TO BULKHEAD GROUND

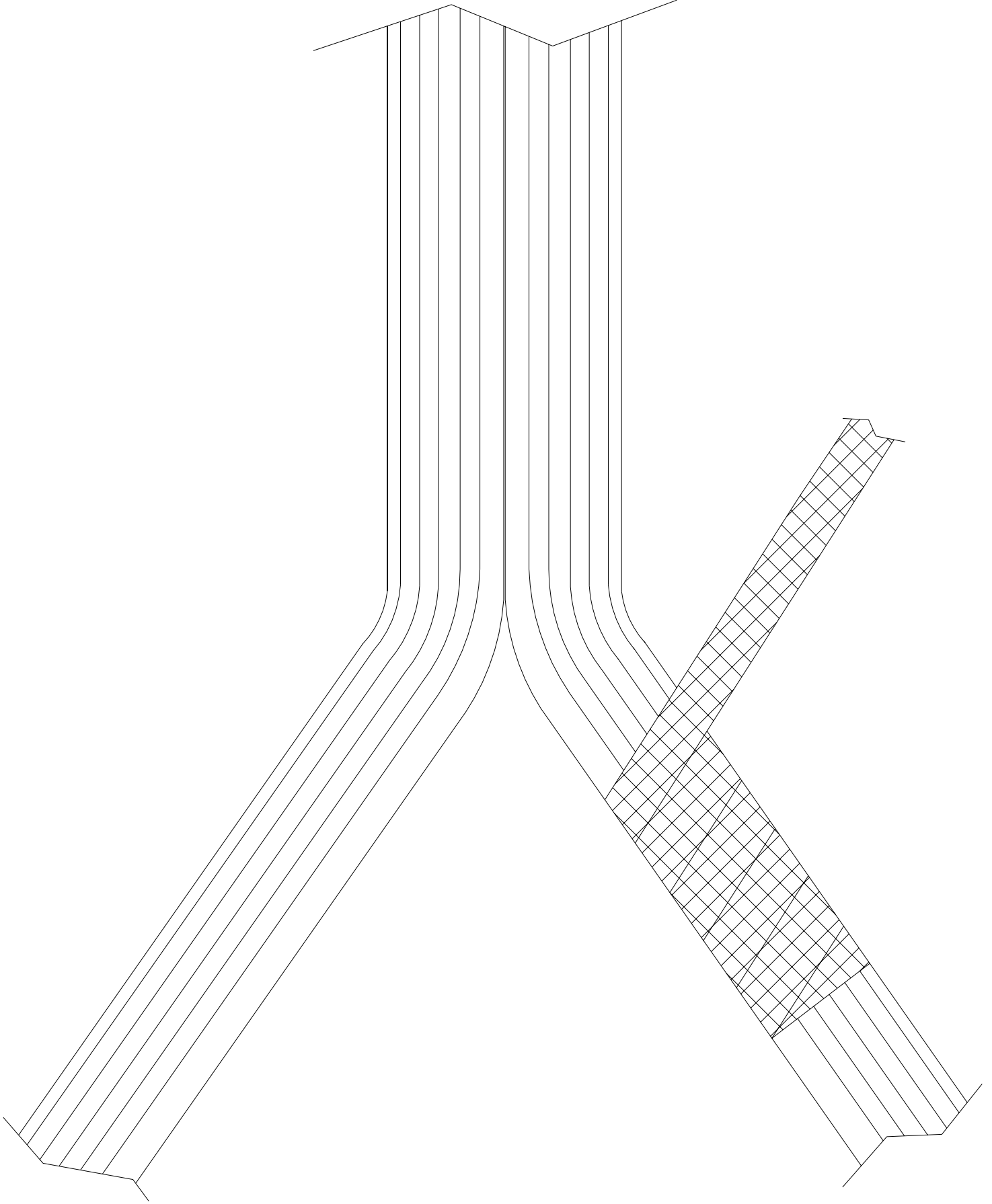

FIGURE 12. SHIELD TAPE ON TRANSITION OR BREAKOUT

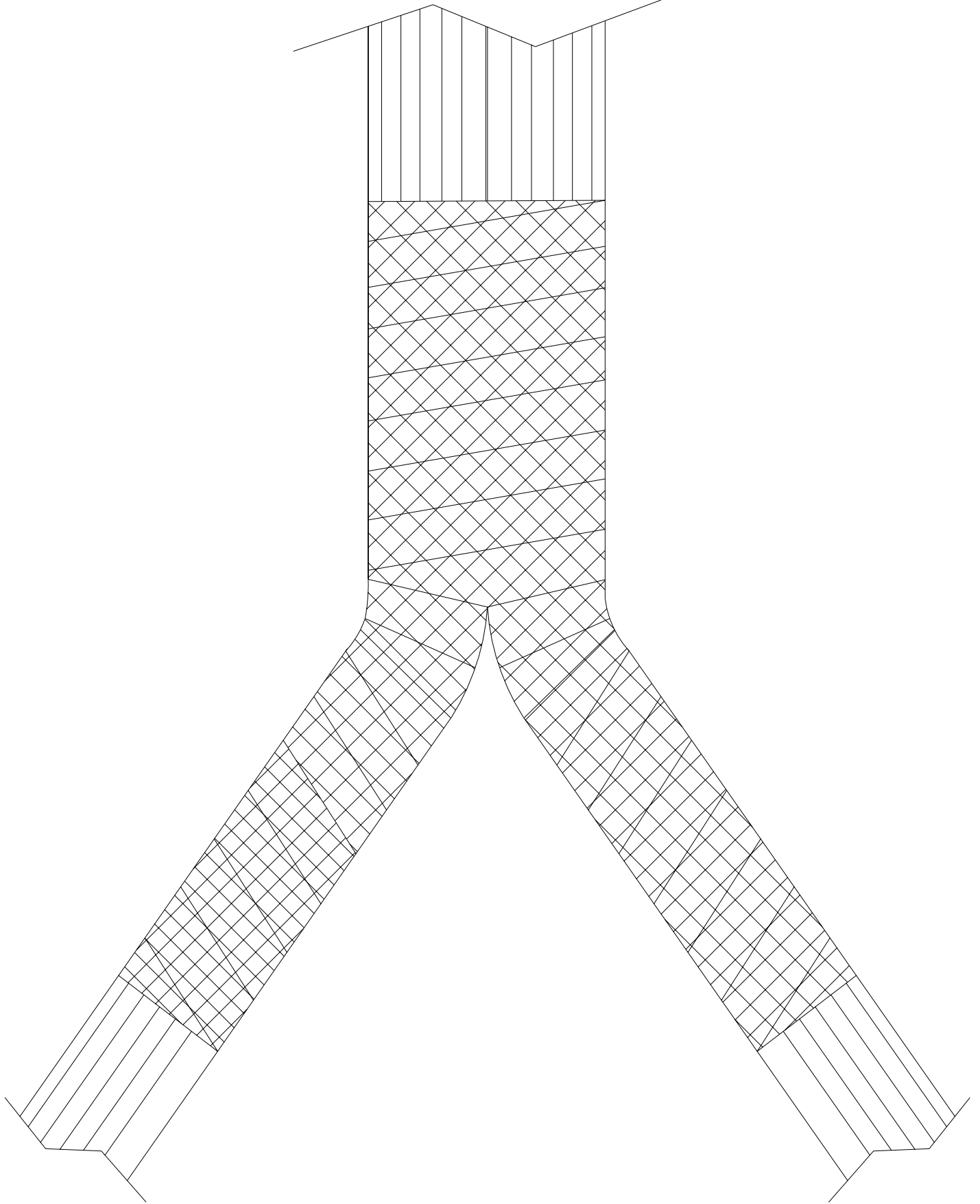

FIGURE 13. FINISHED EMI TAPE WRAP

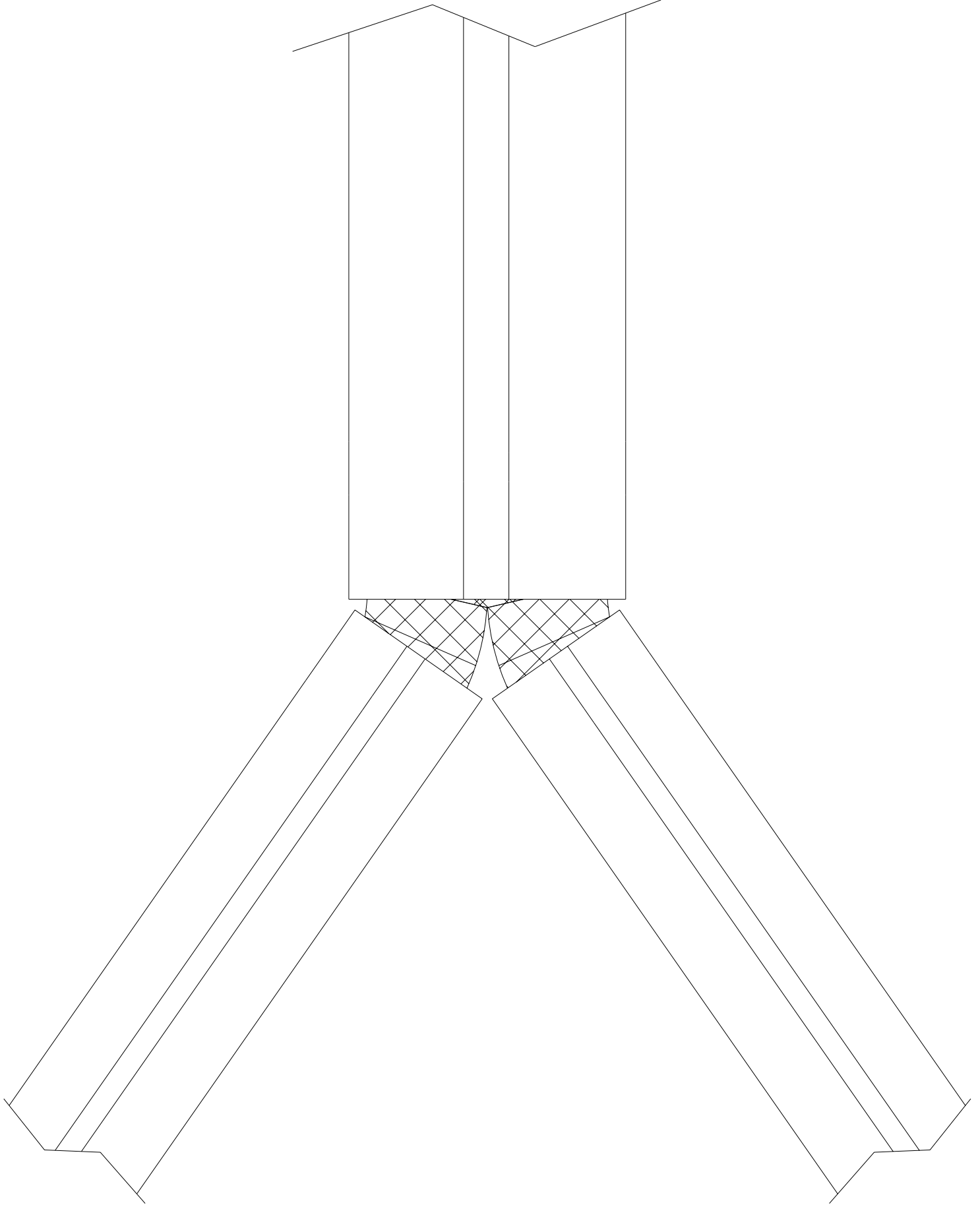

FIGURE 14. SHIELDED JACKET POSITION

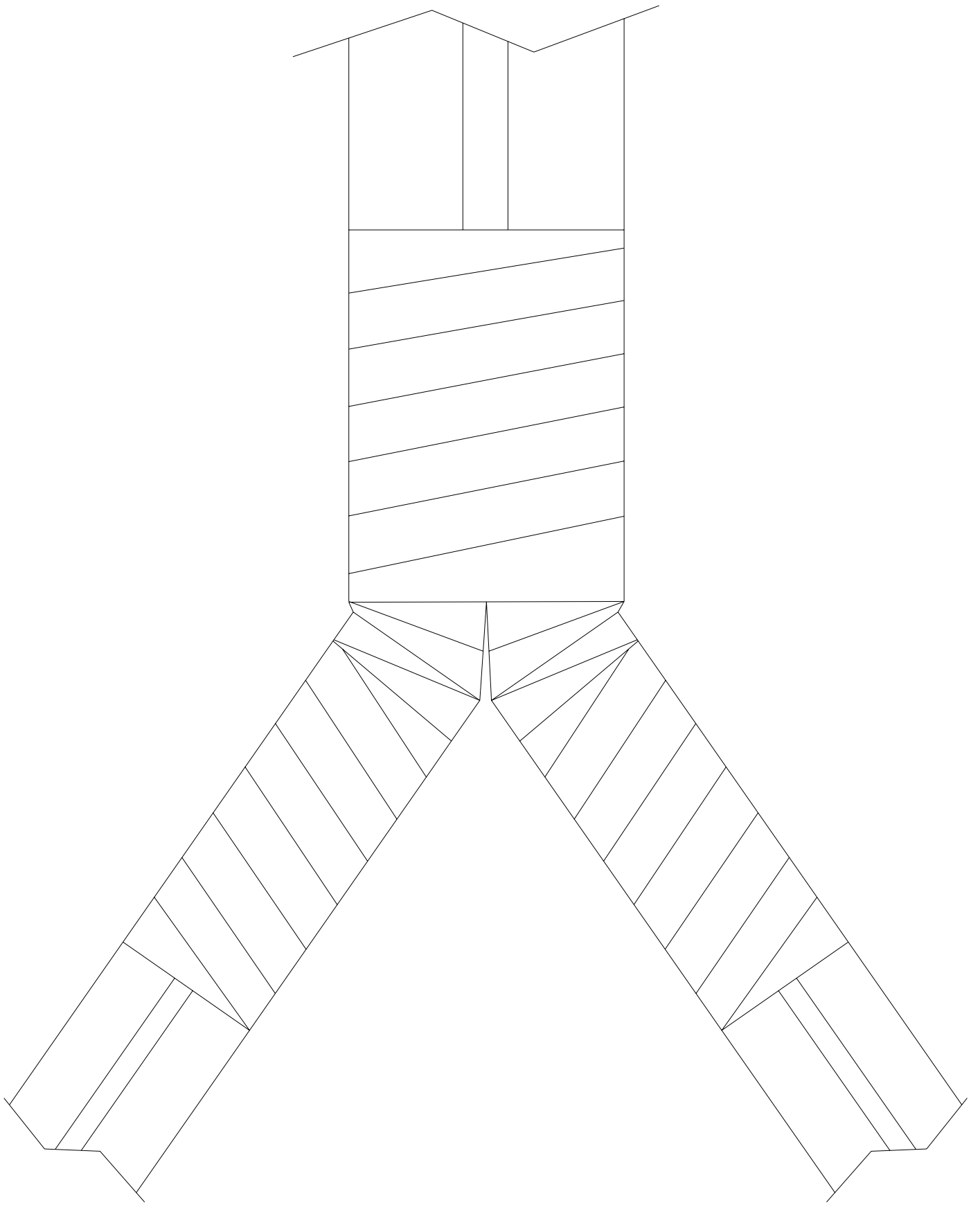

FIGURE 15. ZT-TAPE-8235 INSULATION TAPE WRAP

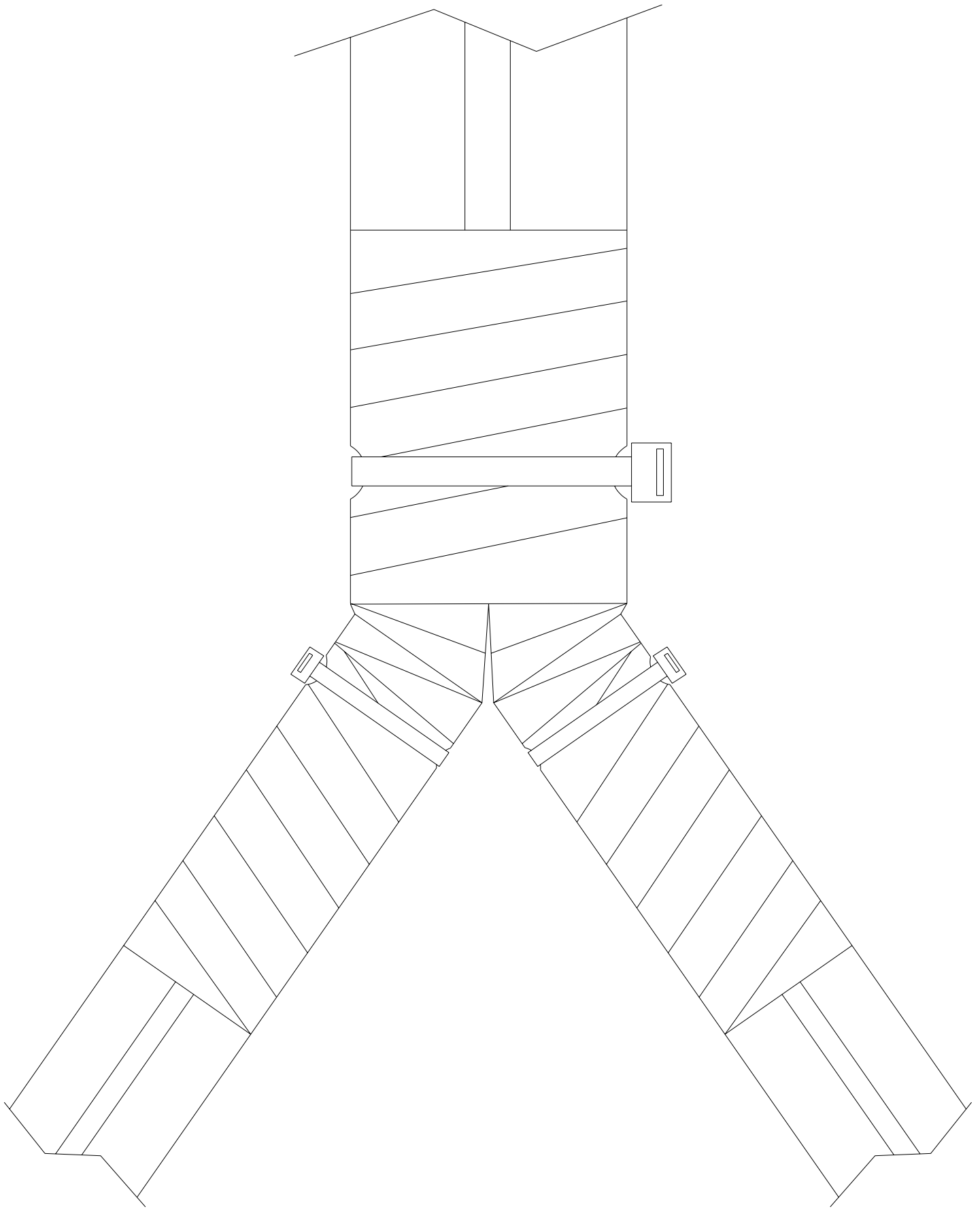

FIGURE 16. FINISHED ASSEMBLY WITH TIE-WRAPS